

**GOODHUE COUNTY PUBLIC WORKS
MAILBOX SUPPORT POLICY**

A. Purpose

Minnesota Statute § 169.072, subd. 3 and Minnesota Rules, Chap. 8818 permit a road authority to remove and replace unauthorized mailbox installations or supports located on highways under its jurisdiction that do not conform to U.S. Postal Service and State requirements. There are many mailbox installations or supports along Goodhue County roads and state aid highways that do not conform to the requirements. It is the purpose of this policy to adopt the state and federal requirements for mailbox installations and/or supports. Enforcement of these requirements in the installation of new mailboxes and the replacement of nonconforming mailboxes will assist the efficient and safe maintenance of county roadways and protect and provide for public safety.

B. Definitions

1. “Mailbox installation” or “installation” means the entire mailbox structure, including the support, mailbox, hardware, and attachments.
2. “Mailbox support” or “support” means the part of the mailbox installation that holds up the mailbox, excluding hardware and auxiliary attachments.

B. Construction Requirements for Mailbox Installations or Supports

All installations and replacements of mailboxes, including supports, shall be constructed and situated in conformance with Minnesota state requirements as set forth at Minn. Stat. § 169.072 and Minn. Rules Chap. 8818, as amended. Said requirements are not subject to frequent change and copies are available from the Goodhue County Public Works Department.

D. Replacement of Mailbox Supports – During County Highway Construction Projects

1. All mailbox supports not conforming to the state and U.S. Postal Service requirements shall be replaced by Goodhue County at the time a Goodhue county road or state aid highway along which they are located is reconstructed or resurfaced (with pavement or aggregate) unless otherwise stipulated within this policy. The cost of replacing the supports shall be borne by Goodhue County.
2. The existing mailbox will be installed on the new support if it is of a type consistent with state and U.S. Postal Service requirements. If the mailbox is nonconforming, the owner or resident shall replace it with a mailbox meeting the state and U.S. Postal Service requirements. At the time of the County’s installation of a new support, the owner or resident may substitute, at their expense, a new mailbox meeting state and U.S. Postal Service requirements

E. Replacement of Nonconforming Mailbox Installations and Supports

All mailboxes or supports identified as nonconforming by the County, as defined by Minnesota Rules 8818, shall be replaced. The owner or resident shall be given notice, personally or by certified mail to the address served by the mailbox, of the County’s intent to remove and replace the non-conforming installation or support. The County may remove and replace a nonconforming installation or support not less than sixty (60) days after giving said notice and charge the Owner up to the maximum defined by Minnesota Statute 169.072. Owners may purchase standard swing-away type mailbox supports from the County in an amount as stated on the County’s Annual Fee Schedule.

F. Replacement of Mailbox Installations or Supports Damaged by Goodhue County

The Goodhue County Public Works Department shall replace a mailbox installation or support damaged during snowplowing operations or other maintenance activities with a standard size mailbox on a support that meets state requirements provided:

1. The mailbox was properly installed according to U.S. Postal Service and County requirements, and
2. The mailbox installation or support is physically struck by County equipment

Replacement mailboxes and mailbox supports will be standard swing-away type mailbox supports and mailboxes. Unless determined reasonable by the County Engineer, the County will not repair or replace supports damaged by snow or ice pressure from snow plowing operations without physical contact with the equipment, or damage from third parties.

G. Mailbox Installation and Support Requirements in New Subdivisions

All mailbox installations set up within a new subdivision shall be constructed in accordance with U.S. Postal Service and state requirements if installed along county roads or county state aid highways. Where possible, mailbox installations shall be located on subdivision streets and not on county roads or county state aid highways.

H. Ownership and Maintenance of Replaced Mailbox Installations or Supports

The County does not issue permits for the placement of mailboxes within the road right-of-way. All mailboxes placed with the road right-of-way are placed there at the Owner's risk. Replacement of mailbox installations or supports by Goodhue County does not result in any change of ownership. All future maintenance and replacements of the mailbox installation shall be the responsibility of the owner or resident and shall be done to conformance standards.

I. Interruption of Mail Delivery

The County's removal and replacement of a mailbox installation or a support shall be done in such a manner as not to cause interruption of mail delivery, if possible.

J. Aggregation of Mailboxes

The County shall replace nonconforming multi-mailbox installations or supports with conforming installations, so as to perpetuate aggregation of mailboxes to the greatest extent possible.

K. Newspaper/Circular/Advertising (Non-Mail) Delivery Boxes

All boxes or receptacles for the delivery of newspapers, circulars, advertisements and other non-mail items shall be attached to the mailbox support, if one exists, but not below the height of the mailbox. If there is no mailbox support, any such support for the receipt of non-mail items shall meet the requirements of the State regarding mailbox installations. The area underneath the mailbox shall remain free of obstructions. The County shall replace any non-mail delivery boxes it damages under the same terms and conditions as section E above.

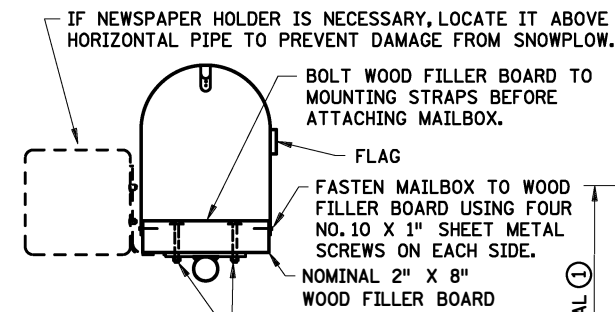

WOOD FILLER BOARD FASTENED TO MOUNTING STRAPS USING FOUR 1/4" DIAMETER X 2 1/2" LONG CARRIAGE BOLTS.

SECTION A-A

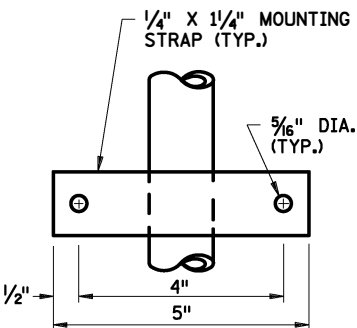

TOP VIEW

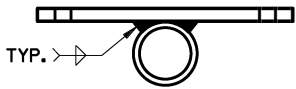

END VIEW

MOUNTING STRAP



TOP VIEW

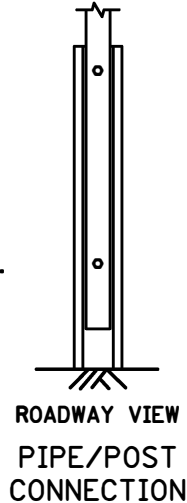

**ROADWAY VIEW
PIPE/POST CONNECTION**

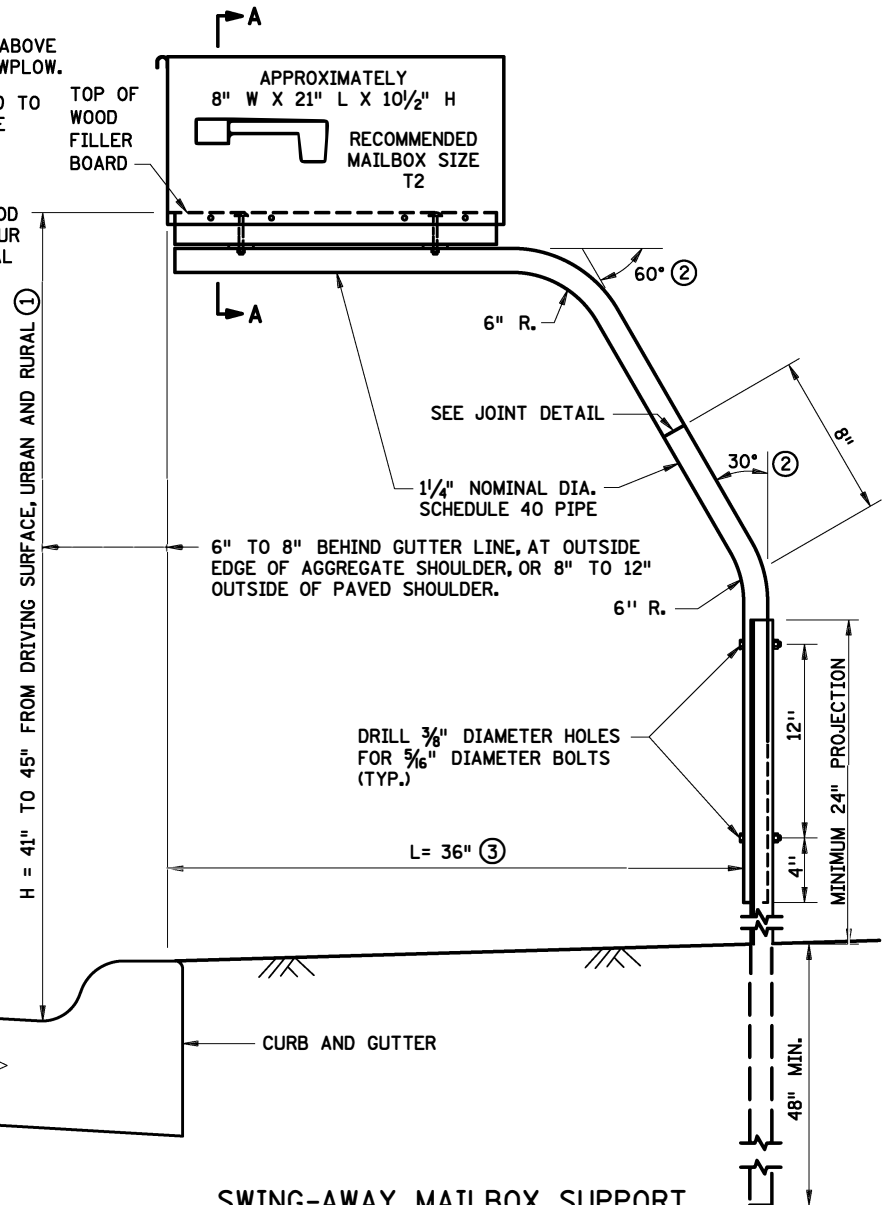

SWING-AWAY MAILBOX SUPPORT

NOTES:

STAKE MAILBOX LOCATIONS BEFORE INSTALLATION FOR PROPER HEIGHT AND DISTANCE FROM THE ROADWAY. ONCE STAKED, THE INSTALLER MUST NOTIFY THE ENGINEER AND THE POST OFFICE. THE ENGINEER AND THE POSTMASTER SHALL APPROVE THE STAKED LOCATIONS PRIOR TO FINAL INSTALLATION.

THE MINIMUM SPACING (CENTER TO CENTER) BETWEEN MULTIPLE MAILBOX SUPPORTS SHALL BE EQUAL TO THE HEIGHT OF THE MAILBOX SUPPORT.

OTHER MAILBOX SUPPORT DESIGNS MAY BE USED IF THEY SATISFY NCHRP REPORT 350 OR MASH CRITERIA IN ACCORDANCE WITH FHWA ACCEPTANCE LETTER, MEET MINNESOTA RULES 8818 AND U.S. POST OFFICE RECOMMENDATIONS AND ARE IN COMPLIANCE WITH MNDOT REQUIREMENTS WHICH MAY INCLUDE THE FOLLOWING (REQUIRED ON TRUNK HIGHWAYS):

PIPE SHALL CONFORM TO SPEC. 3362, SCHEDULE 40 OF ASTM A53/A53M.

ALL FASTENERS SHALL CONFORM TO SPEC. 3391.

PIPES, POST, AND OTHER STEEL COMPONENTS SHALL BE GALVANIZED PER SPEC. 3392.

THE CONTRACTOR SHALL SEND THE SHOP DRAWINGS TO THE ENGINEER FOR APPROVAL. FOR QUESTIONS REGARDING DESIGN ELEMENTS AND BREAKAWAY FEATURES, CONTACT THE DESIGN STANDARDS UNIT.

- ① HEIGHT OUTSIDE THIS RANGE (H) MUST BE APPROVED BY LOCAL POSTMASTER.
- ② 45-DEGREE BENDS MAY BE USED AS AN OPTION.
- ③ A 48" OR 53" CANTILEVER LENGTH (L) MAY BE USED AS AN OPTION FOR NON-TRUNK HIGHWAY USE.

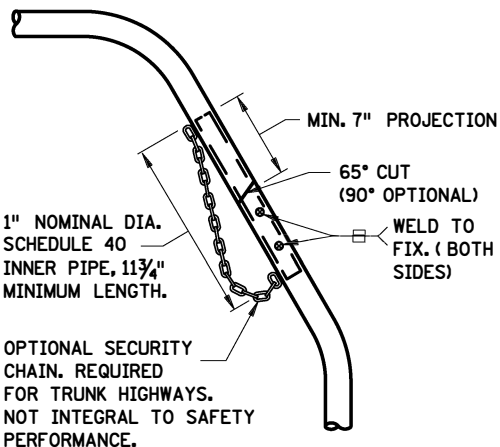

JOINT DETAIL

APPROVED 07-16-2021

 STATE DESIGN ENGINEER

STATE OF MINNESOTA
 DEPARTMENT OF TRANSPORTATION
MAILBOX SUPPORT
 SWING-AWAY TYPE

SPECIFICATION
 REFERENCE
 3362 3391
 3392 3401

STANDARD
 PLATE
 NO.
9350B

***Unsafe mailbox installations
cause property damage, injury
and even death.***



Awareness

No one wants to be responsible for a fatality, but sometimes the public is not aware of what might be a safety concern. Mailboxes (specifically their



support tubes) often are constructed as a home decoration or are constructed to withstand snow removal efforts; unfortunately some of these designs are roadside hazards. To address this issue, State Legislation was enacted in 1991.

Legislation

Under Minnesota Statute 169.072 and Minnesota Rule 8818, local road authorities have the ability to develop and adopt rules regarding mailbox installations. The law, enacted by the 1991 Minnesota legislature, advises that mailbox installations should meet both national and Federal Highway Administration (FHWA) standards and recommendations regarding breakaway installations and location. Installations that do not meet the standards and

recommendations may be removed and replaced at the owner's expense by the local road authority.



Steps for Replacing a Hazardous Mailbox

The general procedure for bringing a hazardous mailbox into compliance.

- Inform owner/resident that mailbox is non-conforming
- Inform owner/resident of mailbox installation standards
- Provide timeframe for replacement or modification
- If owner does not comply, agency will replace mailbox and may bill owner

***Example of Preferred Installation -
Minnesota Swing-Away Mailbox***



Acceptable Installations

Please contact your city or county engineer and post office for recommended specific installations. In general, installations should be light in weight, yet sturdy enough to resist sagging and able to stand up to snow thrown by snowplows. Moreover, they should break away when struck by an errant vehicle.

Accepted supports include:

- Swing away type installation (preferred)
- 4 x 4-inch wooden post (maximum size) or a 2-inch or less diameter metal pipe
- Minimum spacing between multiple box supports is 30 inches

Current standards allow no more than two mailboxes per single support; if more than two mailboxes are on a single support, support must meet national crash tests.



4 x 4-inch Wooden Post



2-inch diameter metal pipe



Coat Hanger Mailbox

For additional information about proper mailbox installations, go to:
www.lrrb.gen.mn.us

MINNESOTA LOCAL ROAD RESEARCH BOARD



Examples of Unsafe Installations

For the safety of the traveling public, the following installations are considered to be a road hazard on roads with a posted speed limit of 40 mph, or greater.

The following list illustrates examples of prohibited mailbox installations.

- 1) Installations with more than one vertical support.
- 2) A single support containing more than two mailboxes unless specifically approved by local road authority.
- 3) A mailbox that is not U.S. Postal Service approved.
- 4) Adjacent installations whose supports are closer than 30 inches measured from center-of-post to center-of-post.
- 5) Any neighborhood delivery or collection box unit (cluster boxes).
- 6) A support using unsafe materials stronger than the wooden 4 x 4-inch post or 2-inch diameter metal pipe.
- 7) Supports or mailboxes that encroach on a lane or shoulder of the roadway.



Is Your Mailbox a
Hazard?

